



Data sheet

Pressure Control Type KPU



KPU pressure controls are designed for use in refrigeration and air-conditioning systems to protect the systems from excessively low suction pressure or too high discharge pressure. They can also be applied to start and stop compressors and the fans of air-cooled condensers.

KPU pressure controls, in single and dual versions cover a comprehensive range of applications, and are designed for use with HCFC and non-flammable HFC refrigerants.

Features

- Snap action electrical contacts minimize chatter, bounce, and wear, and ensure longterm electrical and mechanical reliability
- The fail-safe dual bellows used in KPU 6 and KPU 16 prevent refrigerant loss and enable premature cut-out when a fault occurs
- SPDT or SPST switch a in single control models. SPST or SPDT with high-low pressure signal in dual control models
- Manual trip function (electrical contact function can be tested without the use of tools)
- Easily replaces Johnson Controls and Ranco products
- Wide pressure range: from low pressure KPU 2 with narrow differential to KPU 6 and KPU 16 for high pressure refrigerants (R410A, R744)
- Automatic, manual or convertible reset versions available
- Vibration and shock resistant

Approvals

UL listed for USA and Canada, E31024

Materials in contact with medium

Unit type	Material
KPU 1, KPU 2, KPU 5, KPU 15	Tin bronze, no. CW452K, EN 1652 Nickel plated free cutting steel, no. 1.0737/ 1.0718 to EN 10277
KPU 6, KPU 16	Stainless steel bellows
KPU with capillary tube	Copper SF-CU no. 2.0090 to DIN 1787

Technical data

Ambient temperature		-40 – 122 °F (175 °F for max 2 hours)	
Maximum working pressure	Low pressure (LP) controls	KPU 1, KPU 2 and LP side of KPU 15, KPU 16: 250 psig	
	High pressure (HP) controls	KPU 5 and KPU 15 on HP side: 510 psig	
		KPU 6 and KPU 16 on HP side: 675 psig	
Maximum testing pressure	Low pressure (LP) controls	KPU 1, KPU 2 and LP side of KPU15, KPU16: 290 psig	
	High pressure (HP) controls	KPU 5 and KPU 15 on HP side: 530 psig	
		KPU 6 and 16 on HP side: 725 psig	
Cable entry		7/8 in. cable entry for 1/2 in. male pipe thread connection (conduit boss)	
Contact load	Alternating current	FLA = 24 A @ 120 VAC	24 A @ 240 VAC
		LRA = 144 A @ 120 VAC	144 A @ 240 VAC
		LRA is rated for make only	
Direct current		240 V DC: 12W pilot duty	
Wire dimension		10 AWG maximum	
Enclosure		~NEMA 1	

Ordering
Pressure controls for HCFC and non-flammable HFC refrigerants

Pressure	Control type	Low pressure (LP)		High pressure (HP)		Reset		Contact type	Code no.	
		Range [inHg] [psig]	Differential [psi]	Range [psig]	Differential [psi]	Low pressure (LP)	High pressure (HP)		Connection	
									1/4 in. male flare	3/8 in. cap. tube w. 1/4 in. flare nut
Low	KPU 1	6 in. – 108	10 – 60	—	—	Auto	—	A	060-5231	060-5233
Low	KPU 1	6 in. – 108	10 – 60	—	—	Auto	—	B	060-5236	—
Low	KPU 1B	28 in. – 100	10	—	—	Man. (Min.)	—	A	060-5232	060-5234
Low	KPU 2	6 in. – 73	6 – 30	—	—	Auto	—	B	060-5237	060-5235
Low	KPU 2	6 in. – 73	6 – 30	—	—	Auto	—	A	060-5239	060-5240
Fan cycling	KPU 5	—	—	100 – 465	25 – 85	—	Auto	B	060-5241	060-5242
Dual	KPU 15	6 in. – 108	10 – 60	100 – 465	60	Auto	Auto	C	060-5247	060-5248
Dual	KPU 15B	6 in. – 108	10 – 60	100 – 465	60	Auto	Man. (Max.)	C	060-5249	060-5250

Ordering
(continued)

Fail-safe controls for high pressure refrigerants (R410A, R744) PED 97/23/EC approved according to EN 12263

Pressure	Control type	Low pressure (LP)		High pressure (HP)		Reset		Contact type	Code no.	
		Range [inHg] [psig]	Differential [psi]	Range [psig]	Differential [psi]	Low pressure (LP)	High pressure (HP)		Connection	
									¼ in. male flare	36 in. cap. tube w. ¼ in. flare nut
High	KPU 6W	—	—	100 – 600	58 – 145	—	Auto	A	060-5243	060-5245
High	KPU 6B	—	—	100 – 600	60	—	Man. (Max.)	A	060-5244	060-5246
Dual	KPU 16W	6 in. – 108	10 – 60	100 – 600	60	Auto	Auto	D	060-5251	060-5252
Dual	KPU 16B	6 in. – 108	10 – 60	100 – 600	60	Conv.	Conv.	D	060-5253	060-5254

Contact system and application



Load



Signal option



Bellows movement on pressure rise



Bellows movement on pressure drop

Switch type	Switch action	Application
A SPDT <small>Danfoss 60-1279,10 FW</small>	1. Terminals 1-4 close high and open low Terminals 1-2 can be used as lowpressure alarm 2. Terminals 1-2 open high and close low Terminals 1-4 can be used as high pressure alarm	1. Low pressure cut-out 2. High pressure cut-out
B SPST <small>Danfoss 60-1281,10 FW</small>	Terminals 1-4 close high and open low	1. Low pressure cut-out 2. Condenser fan cycling control
C SPST, dual pressure (LP/HP) <small>Danfoss 60-1280,10 FW</small>	Dual pressure control employs an SPST switch that is open when either high or low pressure beyond the control setting is sensed on the two bellows sensing elements of the control	Dual pressure control Protects the system against too low suction pressure and against too high discharge pressure
D SPDT with LP/HP signal <small>Danfoss 60-1282,10 FW</small>	Contact opens on pressure drop below LP set point (turns on the LP signal light) and on pressure rise above HP set point (turns on HP signal light). Contact action is controlled by two bellows sensing elements. Note: max. contact D rating is 50 VA	Dual pressure control. Protects the system against too low suction pressure (LP cut-out signal on terminal B) and against too high discharge pressure (HP signal on terminal D).

Pressure control setting with convertible reset

	 <small>DANFOSS 60-1096,10</small>	 <small>DANFOSS 60-1098,10</small>	 <small>DANFOSS 60-1097,10</small>	 <small>DANFOSS 60-1096,10</small>
Low pressure	Manual reset. ¹⁾	Automatic reset	Automatic reset	Manual reset
High pressure	Manual reset. ¹⁾	Manual reset	Automatic reset	Automatic reset

¹⁾ Factory setting

Design and function

Pressure control, type KPU

KPU single (KPU 1, KPU 2, KPU 5, KPU 6) without front cover

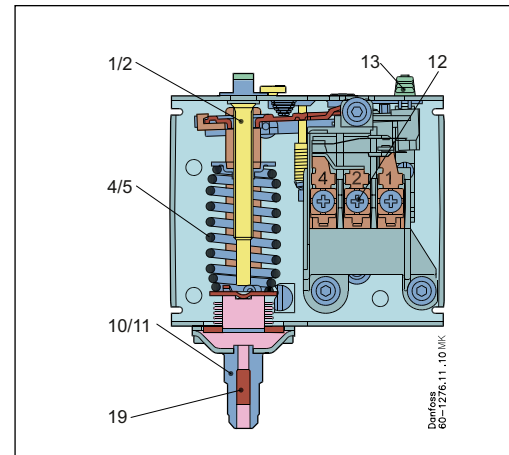
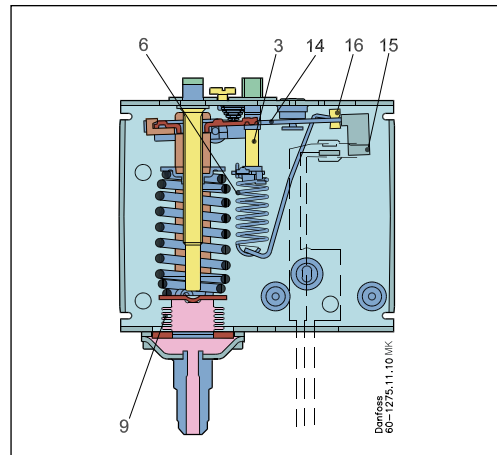

1. Low pressure (LP) setting spindle
2. High pressure (HP) setting spindle
3. Differential
4. Low pressure main spring
5. High pressure main spring
6. Differential spring
7. Ground terminal
8. Cable entry
9. Bellows
10. LP connection
11. HP connection
12. Control terminals
13. Reset button
14. Arm
15. Switch
16. Tumbler
17. Locking plate
18. Contact housing
19. Damping device

KPU dual (KPU 15, KPU 16) without front cover

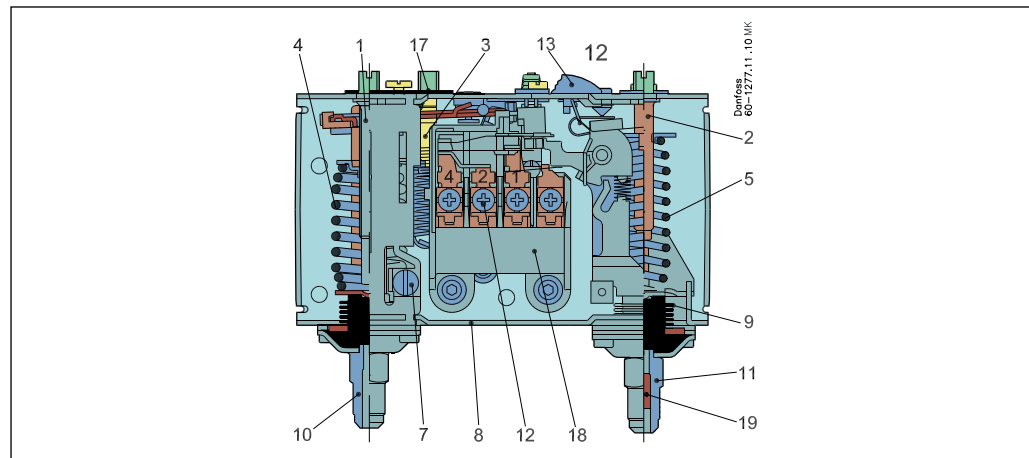

Switch function

The switch in KPU control has a snap-action function and the bellows moves only when cut-in or cut-out set point is reached.

This design has following advantages:

- high contact load
- ultra-short bounce time
- long mechanical and electrical lifetime
- high resistance to pulsation and vibrations

Reset

Version with automatic reset cut-in again automatically when the pressure falls or rises to the set point minus differential.

Version with manual reset have to be cut in manually with external reset button when the pressure in KPU 1 rises min. 10 psi above the set point value, and in KPU 6 falls min. 60 psi under the set point value.

All KPU pressure controls operate independently of changes in ambient temperature around the control. Therefore the setting for cut-out pressure and differential stay constant unless the permissible ambient temperature is exceeded.

Fail-safe bellows concept in KPU 6 and high pressure side of KPU 16.

1. Pressure connection
2. Regulating bellows
3. Outer bellows

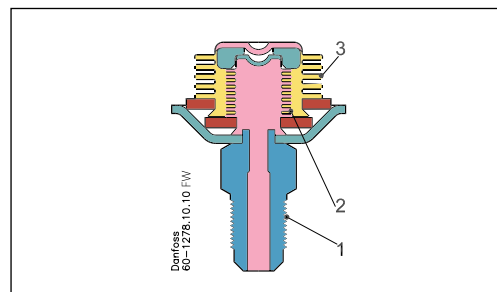

KPU 6 and high pressure side of KPU 16 have double bellows: an outer bellows and a regulating bellows. When system pressure exceeds the set value, the KPU will automatically stop the system. The double bellows system prevents the loss of charge in the event of bellows rupture.

Rupture in the outer bellows causes the control cut-out pressure to fall about 40 psi under the set value, thus providing fail-safe function.

Terminology

Set point

A predetermined value to which a control is adjusted and at which it performs its intended function

Reset

1. Manual reset
A unit with manual reset can only be restored to operational mode by activating the external reset button.
2. Automatic reset
A unit with automatic reset is restored to operational mode automatically.
3. Convertible reset
A unit with convertible reset can be adjusted for either automatic or manual reset.

Maximum working pressure

The maximum permissible pressure for safe functioning of a refrigeration system or any of its parts.

Maximum test pressure

The maximum pressure applied in strength or leakage tests on refrigeration systems or components thereof.

Differential

Differential is the number of psi (or bar) by which cut-in and cut-out set points are separated

Snap function

A specific contact force is maintained until snap is initiated. The time over which contact force reaches zero is a few milliseconds; therefore, contact bounce cannot occur as a result, for example, of slight vibrations before cut-out. The snap-action contact system will continue to function even when micro-welds are created between the contacts during cut-in. The force created to separate the contacts is strong, and instantly shears off all contact surface welds that have been created as the result of cut-in action. These design features ensure that the cut-out point of the KPU control remains very accurate and completely independent of the magnitude of the current load.

Fail-safe control

A control is fail-safe if it has the capability to remain in a safe condition or transition to a safe condition when a fault occurs.

FLA – Motor Full Load Amperes

The current rating, in amperes, of the motor when a full load is applied to it for work being done.

LRA – Locked Rotor Amperes

The current drawn, in amperes, by an electric motor with the shaft or rotor stopped and locked in position.

Setting

Cut-in and cut-out pressures for both LP and HP sides of the system should always be checked with an accurate pressure gauge.

Low Pressure setting for controls with automatic reset

1. Set the LP cut-in pressure on the "CUT-IN" scale (range scale). One rotation of the low pressure spindle ~ 5.2 psi for KPU 2 and ~6.8 psi for KPU 1.
2. Set the LP differential on the "DIFF" scale. One rotation of the differential spindle ~ 3.2 psi for KPU 2 and 2.9 psi for KPU 1.

Note:

The LP cut-out pressure is LP cut-in pressure minus differential value.
The LP cut-out pressure must be above absolute vacuum (Pe = 29.5 in. Hg).

High pressure setting for controls with automatic reset

1. Set the HP cut-out pressure on the "CUT-OUT" scale. One rotation of the HP spindle ~ 22 psi for KPU 5 and ~ 28 psi for KPU 6.
2. Set the HP differential on the "DIFF" scale. One rotation of the differential spindle ~ 5.3 psi for KPU 5 and ~ 8.6 psi for KPU 6.

Note:

The HP restart pressure is equal to HP cut-out pressure minus differential.
Pressure controls with manual reset Set the cut-out pressure on the "CUT-OUT" scale (range scale). Low pressure controls can be manually reset when the pressure is above the cut-out pressure plus the differential. High pressure controls can be manually reset when the pressure is below cut-out minus differential.

**Dimensions [in.]
and weight [lbs]**

KPU with flare connection

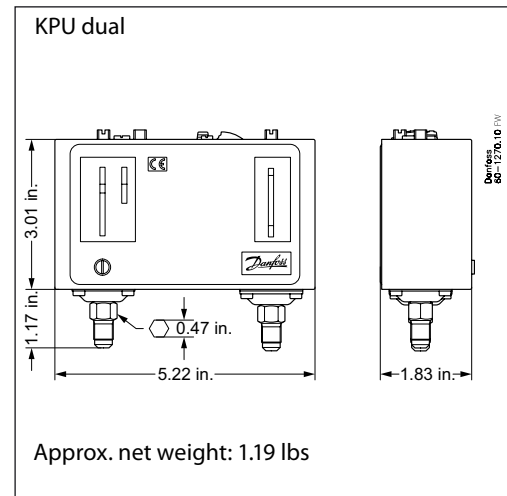
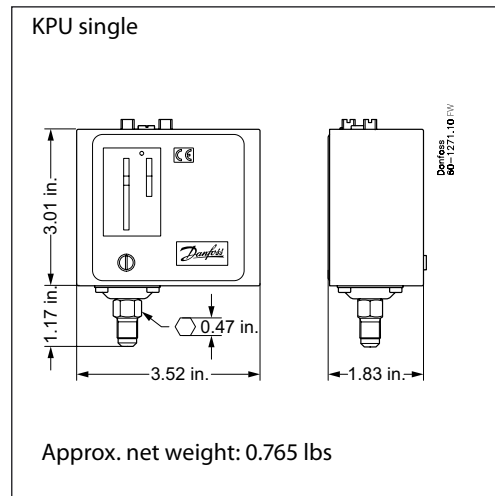

KPU with capillary tube

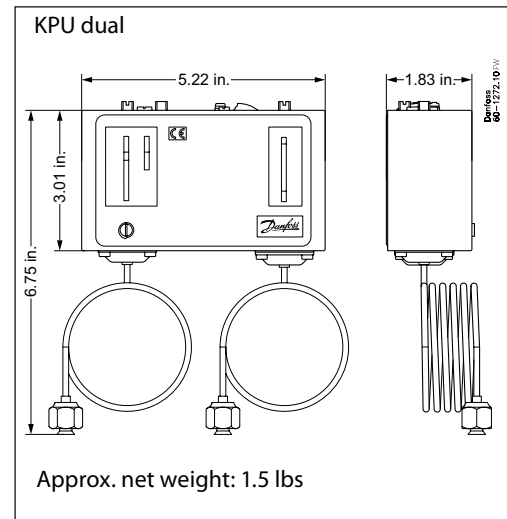
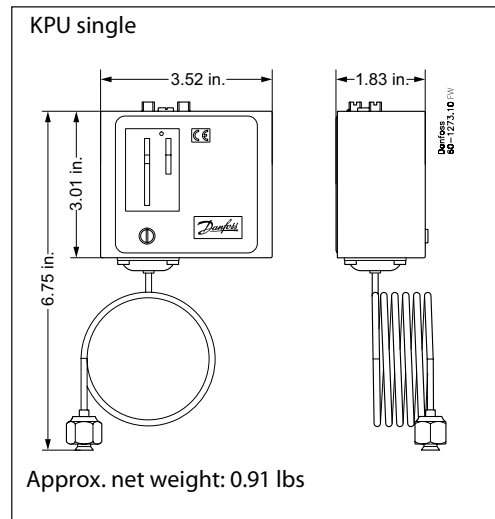

All controls are supplied with universal mounting bracket and mounting screws as standard accessory.

Approximate weight of the bracket and mounting screws: 0.615 lbs